

## ACC ACME Cable Clips

ACME Cable Clips simplify wire management and create a cleaner aesthetic to solar PV arrays. The clips are made of corrosion resistant stainless steel and are designed to prevent damage to cable insulation. The design is easy to install and remove with a flat head screwdriver and can be reused, unlike zip ties. The universal design fits most modules and can hold one or two wires of various diameters.

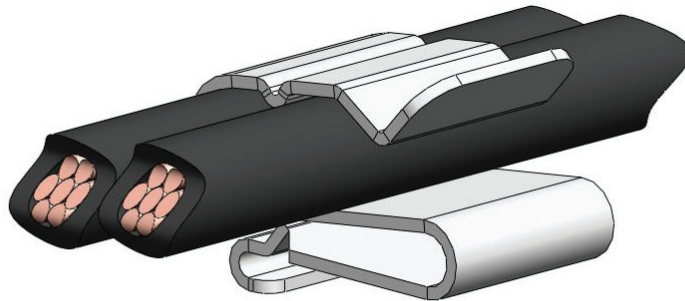

- Made with corrosion resistant 304 Stainless Steel
- Dual wire compartments
- Special tab for easy installation and removal with flat-head screwdriver
- Designed to prevent damage to cable insulation

### ACC



- Clips onto modules
- Holds USE-2 or PV wire
- Wire diameters:
  - 2 wires: 5.0-5.7mm
  - 1 wire: 5.0-7.2mm

### ACC-PV



- Clips onto modules
- Holds PV wire
- Wire diameters:
  - 2 wires: 6.8-7.2mm
  - 1 wire: 6.8-8.0mm