

REV	DATE	DESCRIPTION	ECO	BY	C'H'K.
E	7/9/2015	MARKING UPDATED	40912	GN	SD

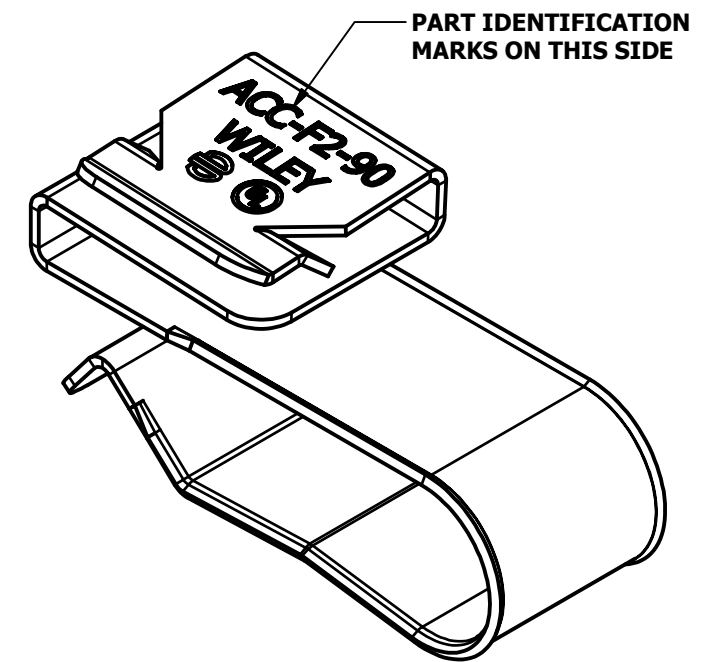
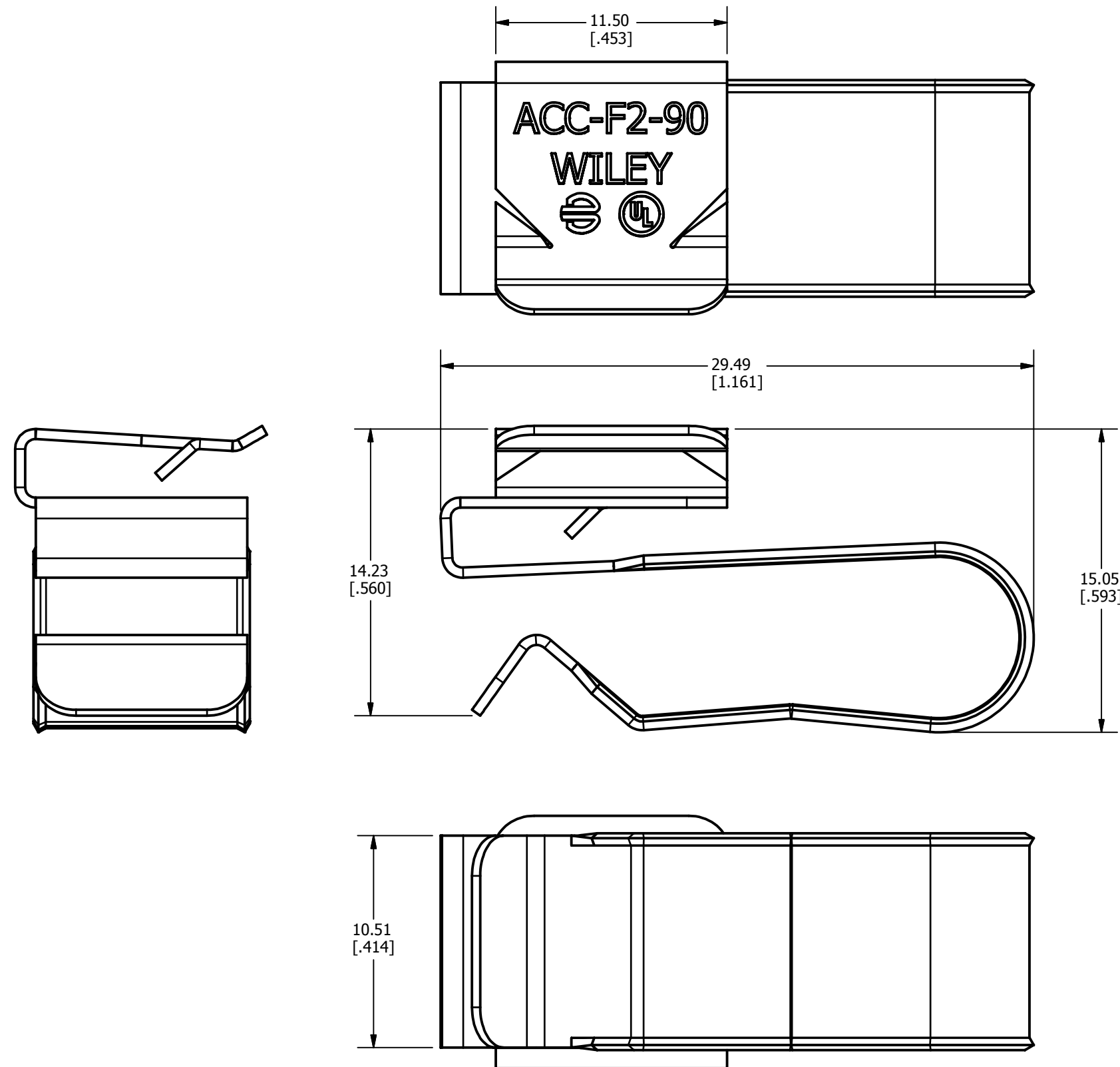

**3D VIEW**

**NOTES:**

1. MATERIAL: 304 STAINLESS STEEL.
2. DIMENSIONS IN BRACKETS [ ] ARE IN INCHES ROUNDED OFF TO THE NEAREST TENTH, UNLESS OTHERWISE SPECIFIED AND ARE FOR REFERENCE ONLY.
3. DESIGNED TO HOLD MICRO INVERTER TRUNK CABLES.
4. LISTED TO UL1565 STANDARD FOR POSITIONING DEVICES.

TO ORDER BURNDY PRODUCTS CALL		ACME CABLE CLIP	
UNITED STATES		ITEM NO: 50042501	
1-800-346-4175 (LONDONDERRY, NH)		CAT. NO: ACC-F2-90	
CANADA:		DRAWN BY: GNATHR 07/9/2015	
1-800-361-6975 (QUEBEC)		CHECKER: E MARTIN 08/27/2015	
1-800-387-6487 (ALL OTHER PROVINCES)		DSN APRVL: E MARTIN 08/27/2015	
FOR PRODUCT INFO: <a href="http://www.burndy.com">http://www.burndy.com</a>		MFG APRVL: --	
		QA APRVL: C KOWALCZYK 08/27/2015	
		MKT APRVL: S PARSONS 09/17/2015	
PROD FAM: WILEY	DRAWING NO	REV	
PROJECT #:	SIZE	50042747	
DOCUMENT TYPE: SALES	B	E	
REL LEVEL: Released		SHEET 1 OF 1	